

SX.438-109 FQ STAPLES SX (18GA)
 USE GENUINE OMER FASTENERS
 P_{s max}: 7,5 bar (105 PSI)
 Crown: .232" 15 - 5/8"
 40 - 1-9/16"

3ETSX438-109FQ

omer s.p.a. CE UK CA
 Via Foresto, 42 - 31058 SUSEGANA (TV) ITALY

3ETCE

WARNING
 1. Read and understand tool labels and manual.
 Failure to follow warnings could result in DEATH or SERIOUS INJURY.
 2. Operators and others in the work area
 MUST wear safety glasses with side shields.
 3. Keep fingers AWAY from the trigger when not driving fasteners to avoid accidental firing.
 4. Choice of trigger systems is important.
 Check manual for triggering options.
 5. NEVER point tool at your self or others in work area.
 6. NEVER use oxygen or other bottled gasses. Explosion may occur.



3ET99

3ET95

2007042L

2007042R

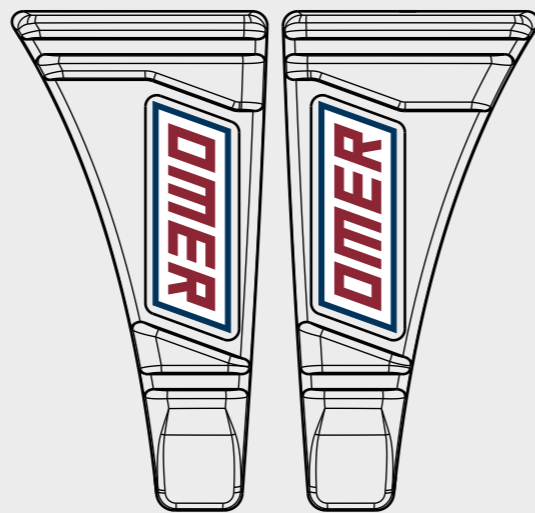

Azionamento - Actuation - Auslösung - Actionnement - Accionamiento - Ενεργοποίηση
 Aciionamento - Activering - Çalıştırma - Aktivierung

Azionamento sequenziale completo
 Full sequential actuation

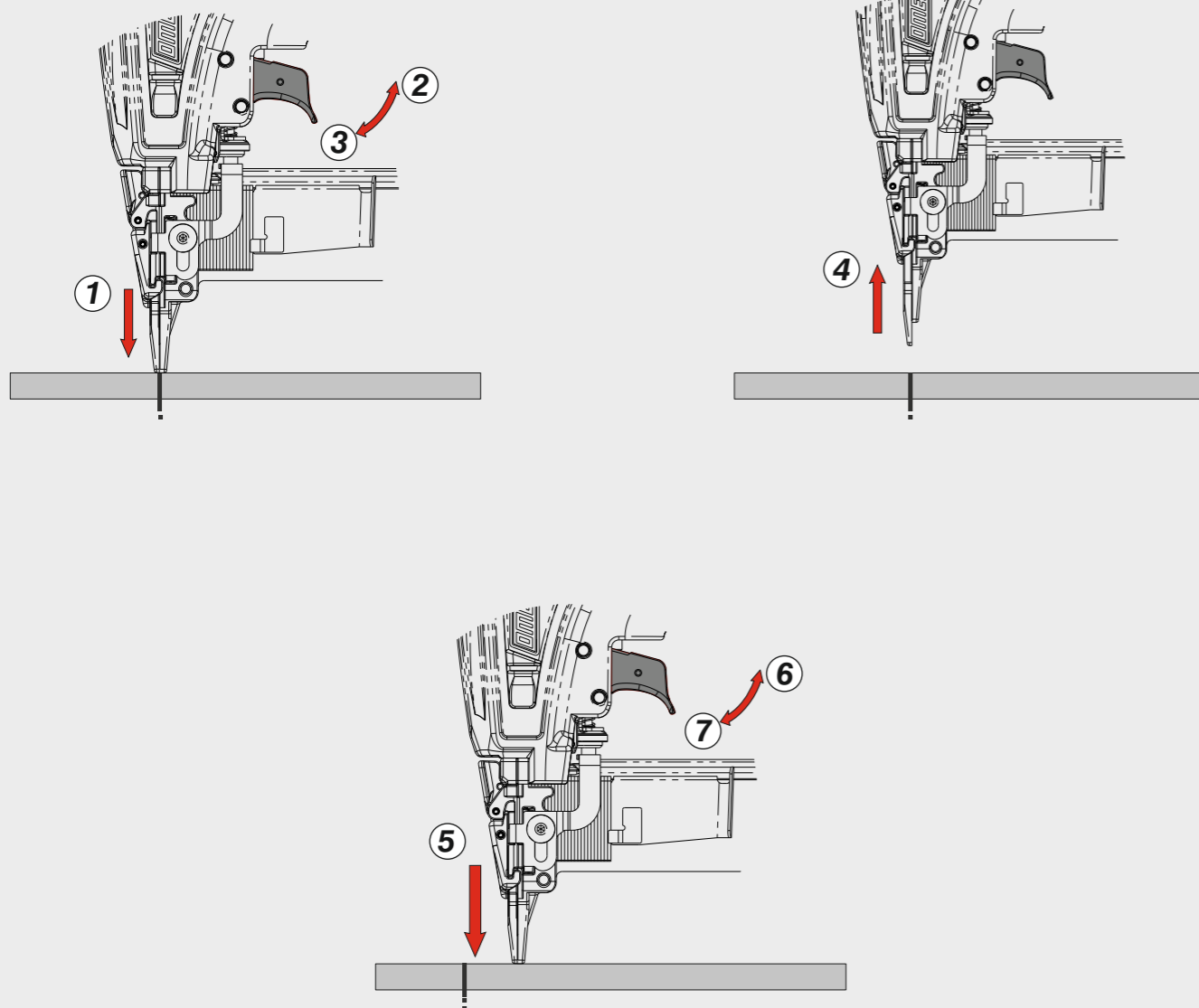

Manuale d'uso, manutenzione e parti di ricambio Parte 2
Manual for use, maintenance and spare parts Part 2
Bedienungs- und Wartungshandbuch sowie Ersatzteilleiste Teil 2
Mode d'emploi, de maintenance et pièces de rechange Partie 2
Manual de uso, mantenimiento y recambios Part 2
Εγχειρίδιο χρήσης, συντήρησης και ανταλλακτικών Μέρος 2
Manual de uso, manutenção e peças sobresselentes Parte 2
Handleiding voor gebruik, onderhoud en wisselstukken Deel 2
Kullanım, bakım ve yedek parça kılavuzu Kısım 2
Användar-, underhålls- och reservdelshandbok Del 2



SX.438-109 FQ



cod. 14470B40109FQ

Dati tecnici Technical data Technische Daten Tekniska data	Caractéristiques techniques Datos técnicos Τεχνικά χαρακτηριστικά	Dados técnicos Technische gegevens Teknik veriler		
Misure impiegabili Lengths Verwendbare Nagellänge Dimensioner som kan användas	Dimensions utiles Medidas de longitud Μήκος Αναλωσίμου	Medidas utilizáveis Toepasbare afmetingen Boy	mm inch	15+40 5/8" ± 1-9/16"
Capacità caricatore n° punti Magazine capacity Magazinkapazität Nägel Magasinkapacitet Antal punkter	Capacité chargeur n° de points Capacidad cargador n° puntos Δωνατοτητα γεμιστερα	Capacidade carregador n° pontos Capaciteit magazijn in aantal spijkers Dergi kapasitesi		105
Pressione d'esercizio Operating pressure Betriebsdruck Drifttryck	Pression d'exercice Presión de servicio Πίεση λειτουργίας	Pressão de serviço Werkdruk Çalışma basıncı	bar psi	5 ÷ 7,5 70 ÷ 105
Consumo aria Air consumption Luftverbrauch Luftförbrukning	Consommation d'air Consumo aire Κατανάλωση αέρα	Consumo ar Luchtverbruik Hava tüketimi	lt/colpo ft³/cycle	0,50 0,0176
Peso Weight Gewicht Vikt	Poids Peso Βάρος	Peso Gewicht Ağırlık	kg lbs	1,25 2,75
Dimensioni Dimensions Abmessungen Dimensioner (AxBxH)	Dimensions Dimensiones Διαστάσεις	Dimensões Afmetingen Boyutlar	mm inch	247x64x255 9-3/4"x2-1/2"x10-1/16" (LxWxH)
EN 12549 :2009 EN ISO 4871 :2009 Pressione sonora in pos. operatore Sound pressure in operator's position Schalldruck am Arbeitsplatz Ljudtryck på operatörsplatsen	Pression sonore poste Opérateur Presión sonora en la pos. del operador Ηχητική πίεση στη θέση του χειριστή	Pressão sonora na posição Operador Geluidsdruk op de werkplaats Operatör pozisyonunda ses basıncı	dB(A)	86 (K= 4 dB)
EN 12549 :2009 EN ISO 3746 :2011 EN ISO 4871 :2009 Potenza sonora emessa Sound power emitted Emitierte Schalleistung Avgiven ljudeffekt	Puissance sonore émise Potencia sonora emitida Εκπεμπόμενη ηχητική ισχύς	Potência sonora emitida Geëmitteerd geluidsvermogen Çıkan ses gücü (ses desibeli)	dB(A)	94 (K= 4 dB)
CEN ISO/TS 8662-11 :2006 EN ISO 5349-2 :2004 EN 12096 :1999 Emissione vibratoria sull'impugnatura Vibratory emissions on handle Emisión de vibraciones en la empuñadura Εκπεμπόμενες δονήσεις στη λαβή	Émission vibratoire sur la prise en main Emisión de vibraciones en la empuñadura Εκπεμπόμενες δονήσεις στη λαβή	Emissão vibratória na empunhadura Trillingsemisssie op de handgreep Tutamak üzerinde vibrasyon emisyonları	m/s²	3,10 (K= 2 m/s²)

Tipo di punto
 Type of fastener
 Befestigungsmittel
 Type de rivet
 Tipo de punto
 Τύπος αναλωσίμου
 Tipo de agrafa
 Type nietjes
 Zimba ve çivi tipleri
 Typ av stygn

SX

0,90x1,25

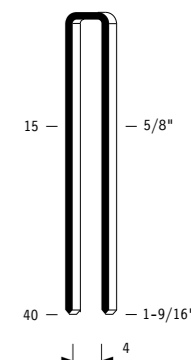

Crown: .232" (1/4")
 Gauge: 18

14470B40109FQ_SX438-109 FQ_4_rev/21_02/06/2023 DV

Parti di ricambio - Spare parts - Ersatzteile - Pièces de rechange - Recambios
Ανταλλακτικά - Partes sobresselentes - Wisselstukken - Yedek parçalar - Reservdelar

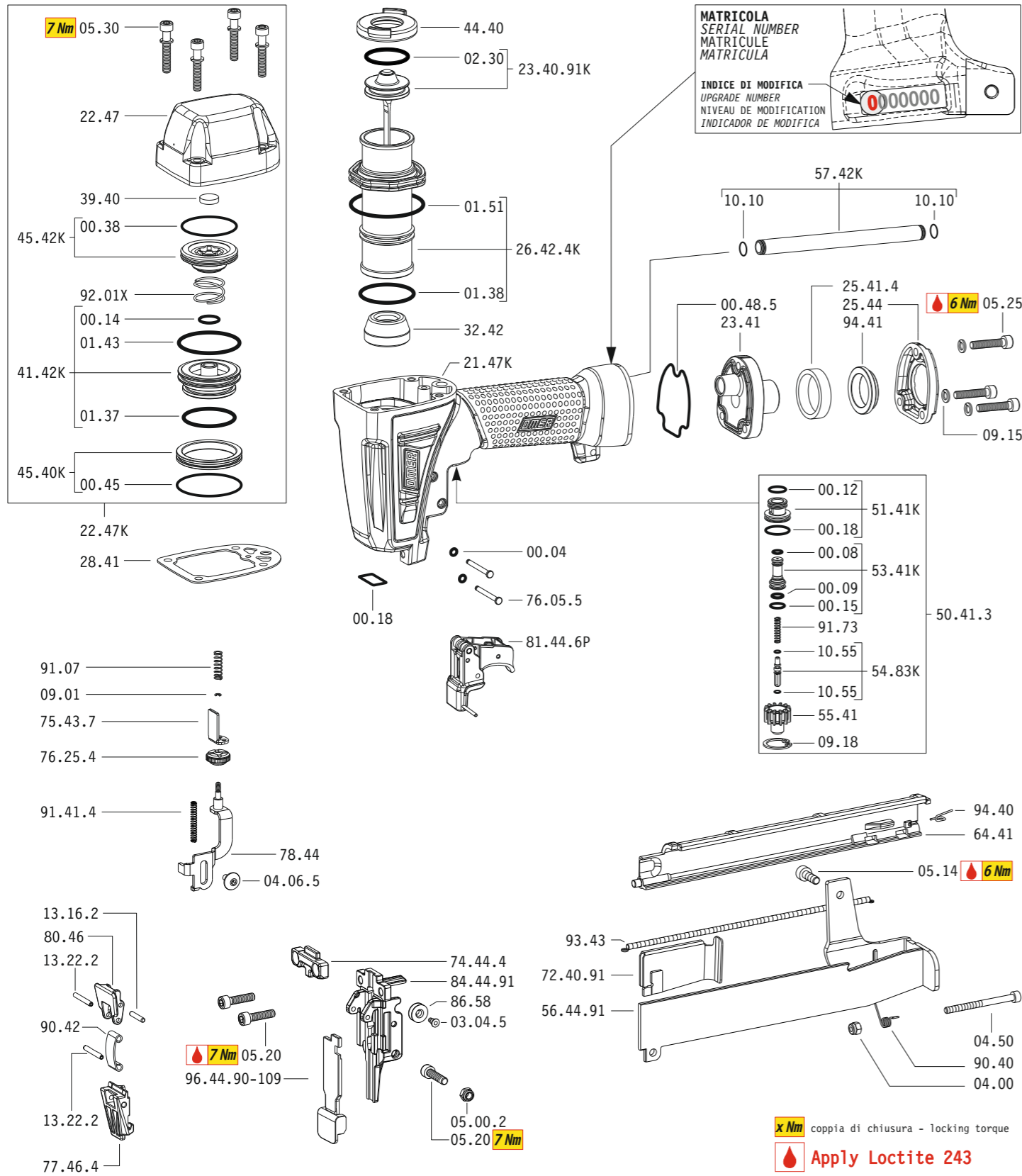

Dotazioni - Equipment - Ausstattung - Outillage - Dotaciones - Εξοπλισμός
Dotações - Uitrusting - Donanımlar - Utrustning

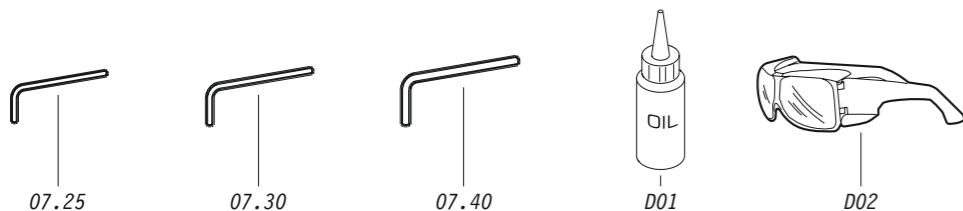

SX.438-109 FQ

cod. 14470B40109FQ

Parti di ricambio - Spare parts - Ersatzteile - Pièces de rechange - Recambios
Ανταλλακτικά - Partes sobresselentes - Wisselstukken - Yedek parçalar - Reservdelar

Cod.	Descrizione	Description
00.04	O-Ring	O-Ring
00.08	O-Ring	O-Ring
00.09	O-Ring	O-Ring
00.12	O-Ring	O-Ring
00.14	O-Ring	O-Ring
00.15	O-Ring	O-Ring
00.18	O-Ring	O-Ring
00.38	O-Ring	O-Ring
00.45	O-Ring	O-Ring
00.48.5	Guarnizione	Gasket
01.37	O-Ring	O-Ring
01.38	O-Ring	O-Ring
01.43	O-Ring	O-Ring
01.51	O-Ring	O-Ring
02.30	O-Ring	O-Ring
03.04.5	Vite	Screw
04.00	Dado	Nut
04.06.5	Vite	Screw
04.50	Vite	Screw
05.00.2	Dado	Nut
05.14	Vite	Screw
05.20	Vite	Screw
05.25	Vite	Screw
05.30	Vite	Screw
07.25	Chiave esagonale	Hex. bar wrench
07.30	Chiave esagonale	Hex. bar wrench
07.40	Chiave esagonale	Hex. bar wrench
09.01	Anello elastico	Elastic ring
09.15	Rondella	Washer
09.18	Anello elastico	Elastic ring
10.10	O-Ring	O-Ring
10.55	O-Ring	O-Ring
13.16.2	Spina	Pin
13.22.2	Spina	Pin
21.47K	Corpo	Body
22.47K	Testa completa	Head unit
22.47	Testa	Head
23.41	Fondello	Case back
25.41.4	Silenziatore	Silencer
25.44	Deflettore	Exhaust deflector
26.42.4K	Cilindro	Cylinder
28.41	Guarnizione	Gasket
32.42	Ammortizzatore	Bumper
39.40	Guarnizione	Gasket
41.42K	Valvola	Valve
44.40	Guarnizione	Gasket
45.40K	Anello valvola	Ring
45.42K	Anello testa	Ring
50.41.3	Pulsante completo	Trigger valve assy
51.41K	Boccola	Valve housing
53.41K	Pistone servovalvola	Valve piston
54.83K	Pulsante	Trigger valve
55.41	Raccordo pulsante	Bush
57.42K	Tubo di scarico	Exhaust pipe
64.41	Carter	Hold down
74.44.4	Staffa testina	Head bracket
75.43.7	Rinvio sicura	Referral safety
76.05.5	Perno	Pin
76.25.4	Regolatore	Controller
77.46.4	Guida testina	Head guide
78.44	Sicura	Safety
80.46	Grilletto testina	Trigger
81.44.6P	Grilletto FQ	FQ Trigger
86.58	Carrucola	Pulley
90.40	Molla	Spring
90.42	Molla	Spring
91.07	Molla	Spring
91.41.4	Molla	Spring
91.73	Molla	Spring
92.01X	Molla	Spring
93.43	Molla	Spring
94.40	Molla	Molla
94.41	Boccola	Bushing
23.40.91K	Battente	Driver
56.44.91	Caricatore	Magazine
72.40.91	Spingipunto	Pusher
84.44.91	Controtestina	Nose
96.44.90-109	Testina	Nose plate
D01	Bocchetta olio	Oiler
D02	Occhiali protettivi	Protective goggles

Guarnizioni - O-Rings - Dichtungen - Joints toriques - Δακτύλιος στεγανοποίησης - Vedantes - O-ringen - Contalar - O-ringar

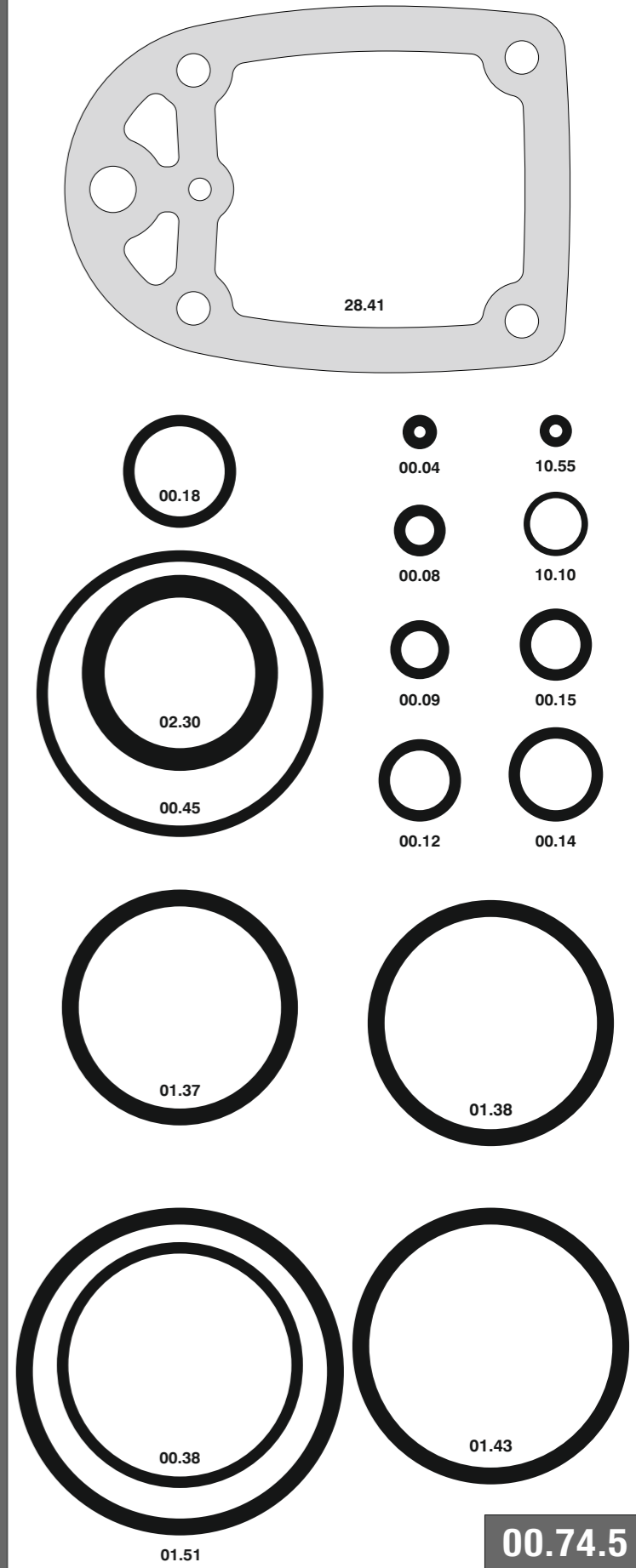

SX.438-109 FQ

cod. 14470B40109FQ

Indice di modifica
Upgrade number

4

Caricamento da sopra
Top load magazine

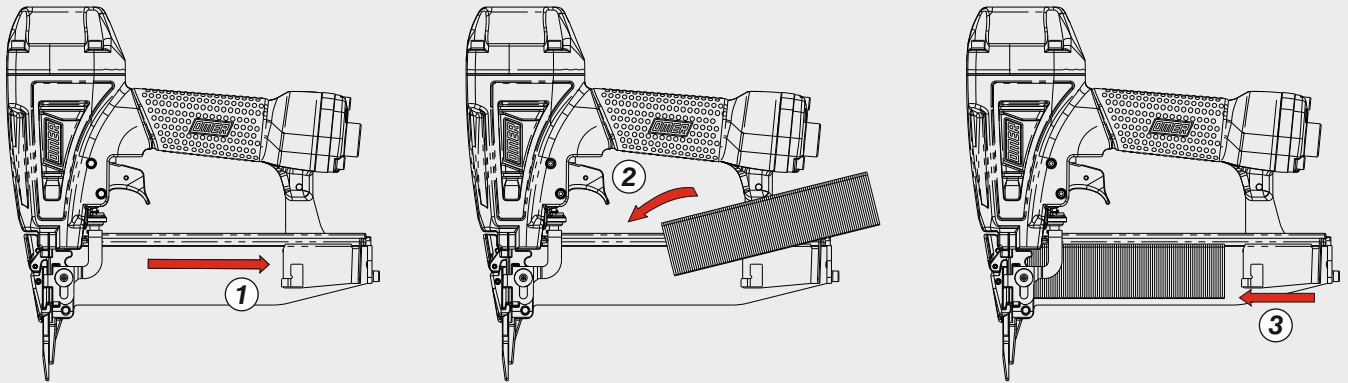

Disinceppamento - Jam clearing - Staubeseitigung - Décoincement - Desatascamiento - Απεμπλοκή
Desencravamento - Deblokkering bij vastlopen - Sıkışma giderme - Rensning av igensättningar

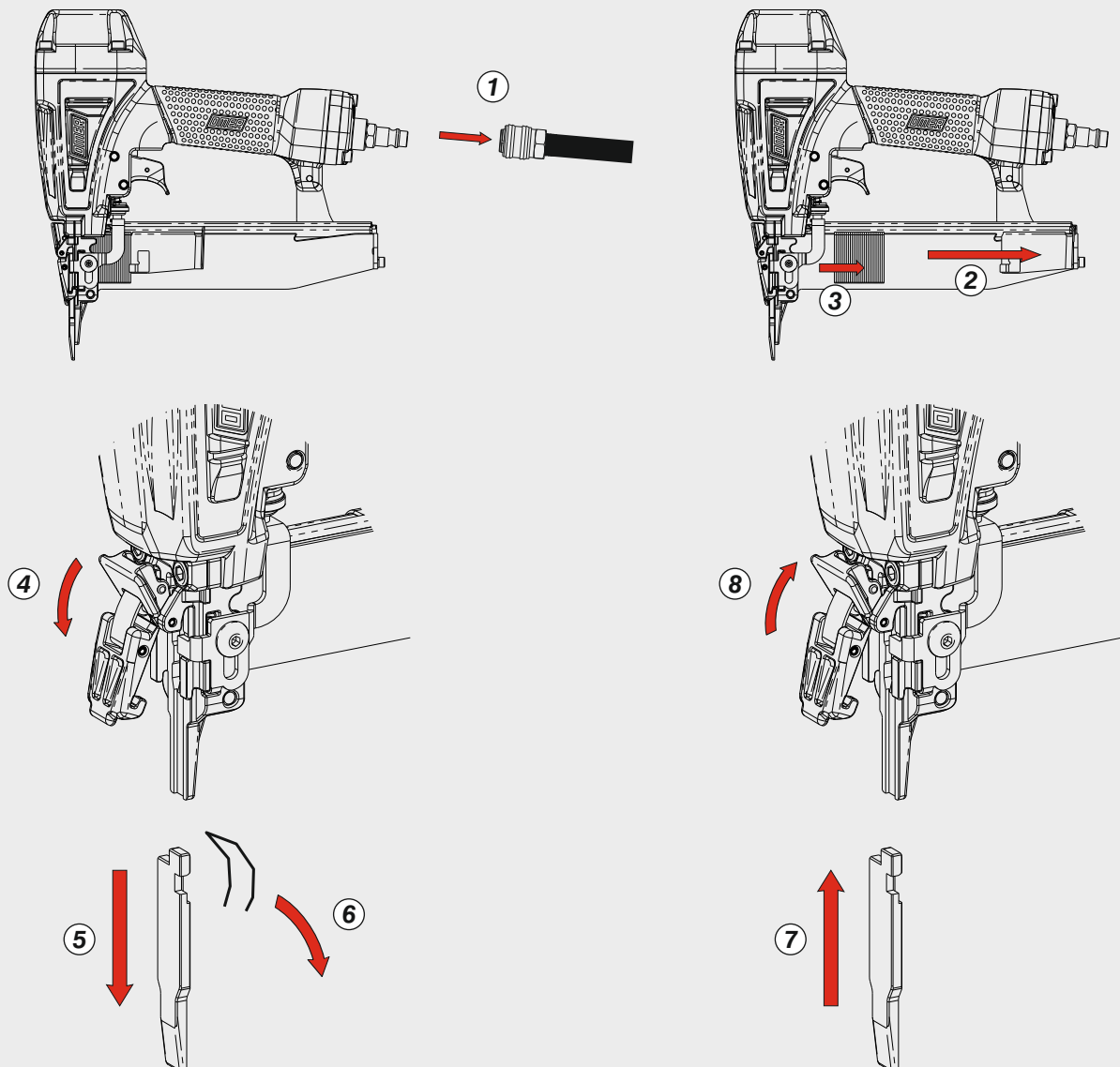

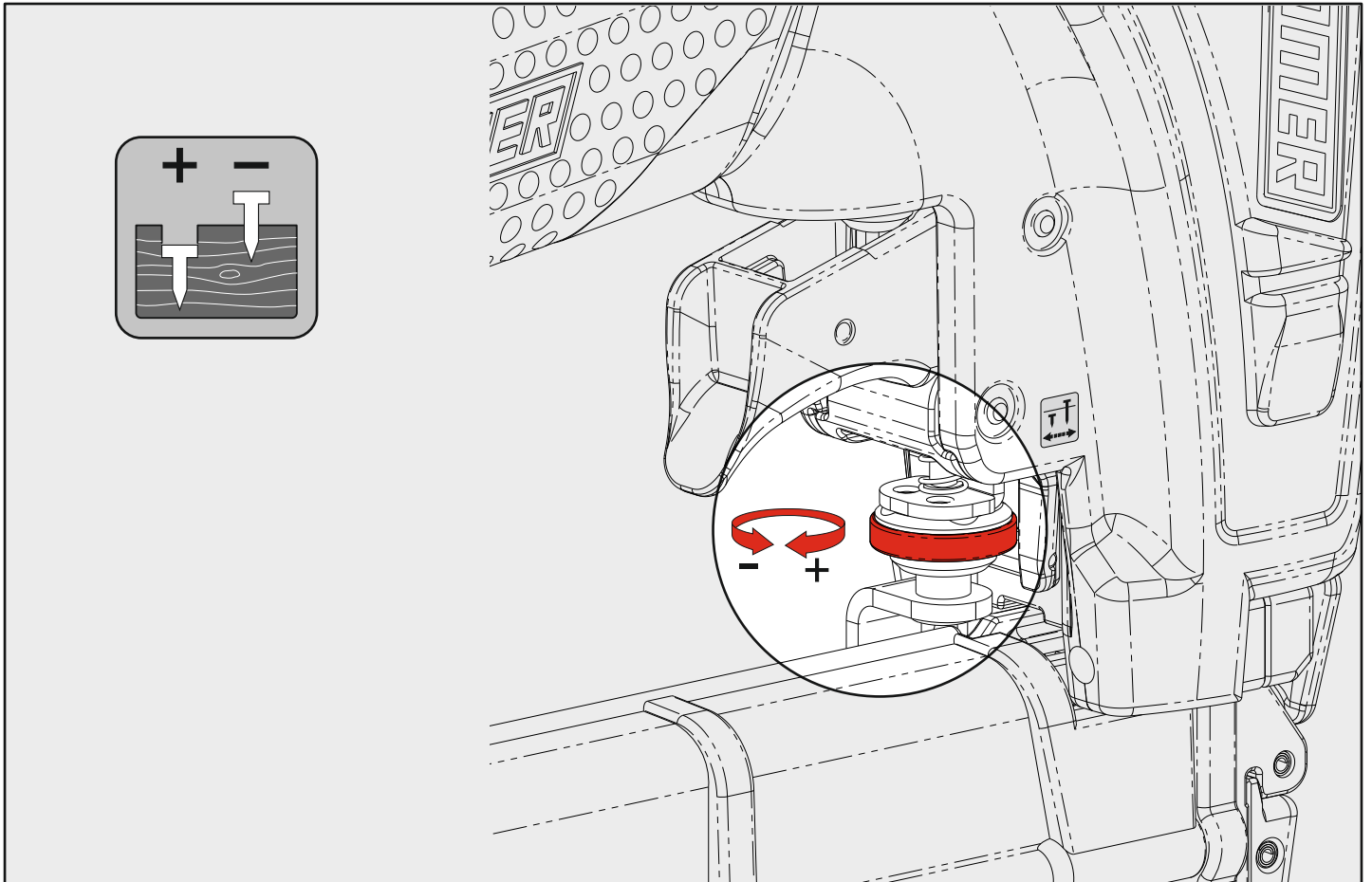

Caratteristiche - Features - Merkmale - Caractéristiques - Características - Χαρακτηριστικά
Características - Kenmerken - Özellikler - Funktionen

Dispositivo di blocco sparo a fine punti
Stop firing device on empty magazine

